

VACON[®] NX

AC DRIVES

BRAKE CHOPPER UNIT (BCU)

APPLICATION MANUAL

VACON[®]

Vacon Brake Chopper Unit application

INDEX

Document code: DPD01565A

Software code: ABFIFF01V122

Date: 22.3.2019

VACON BRAKE CHOPPER UNIT APPLICATION	3
1. Introduction	4
1.1 Operation principle of BCU	4
1.2 Quick start instructions	6
2. Control I/O	7
3. Brake Chopper Application – Parameter lists	8
3.1 Monitoring values (Control keypad: menu M1)	8
3.2 Description of monitoring values	10
4. Parameter list	17
4.1 Basic parameters	17
4.2 Reference Handling	17
4.3 Input signals	17
4.4 Output signals	18
4.5 Protections	20
4.6 Fieldbus parameters.....	22
4.7 ID Control Functions.....	23
4.8 Keypad control (Control keypad: Menu M3).....	24
4.9 System menu (Control keypad: Menu M6)	24
4.10 Expander boards (Control keypad: Menu M7).....	24
5. Description of parameters	25
5.1 Basic parameters	25
5.2 Reference Handling	26
5.3 Input signals	27
5.4 Output signals	29
5.5 Protections	32
5.6 Fieldbus parameters.....	34
5.7 ID Control Functions.....	35
5.8 Keypad control	36
6. Fieldbus Profile for Vacon brake chopper unit	37
6.1 Signals from Overriding System to Vacon regenerative Drive.	37
6.2 Signals from Vacon Drive to Overriding system	37
6.3 Main Control Word	38
6.4 Main Status Word	38
7. Problem Solving	39
8. Fault codes	40

1. INTRODUCTION

1.1 Operation principle of BCU

When you want to slow down a running asynchronous motor fed by a frequency converter it turns into a generator, feeding energy back into the frequency converter. The energy increases the voltage in the DC-link. The frequency converter compensates for this increase by increasing the output frequency, decreasing the instantaneous slip and increasing the motor load. The deceleration is, in this case, dependent on the power losses in the converter and in the motor. This is usually sufficient in most cases, for pumps, fans, conveyors etc. where the kinetic energy in the load is small or the braking time is not critical.

When you have to brake down the motor faster than the losses allow, you have to use BCU module and an external brake resistor (or resistors) for energy dissipation. The extra energy from the load is turned into heat in the brake resistor. If the DC link voltage increases too much, the BCU turns on and discharges the capacitors through the brake resistor. Applications where dynamic braking is usually needed include centrifuges, cranes, some conveyors and drives requiring very fast reversing.

Modules can be connected parallel with other BCU modules in order to increase braking capacity (Figure 1).

In BCU application you can use either Analogue input or OPT-B8 option board for PT100 sensor connection.

Start-up sequence of BCU application has been illustrated in Figure 2.

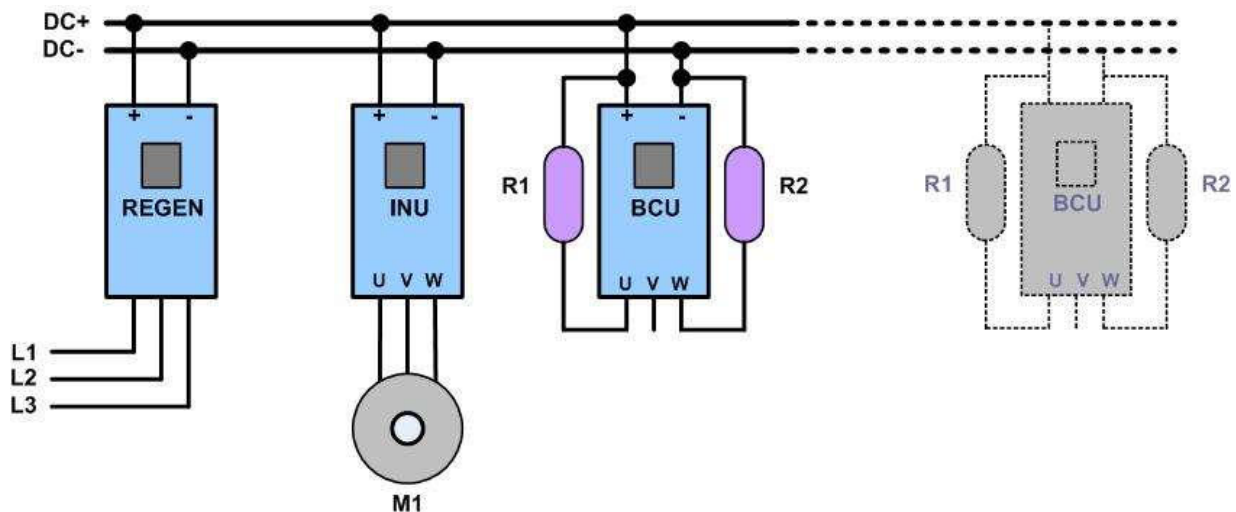

Figure 1. BCU in common DC bus system

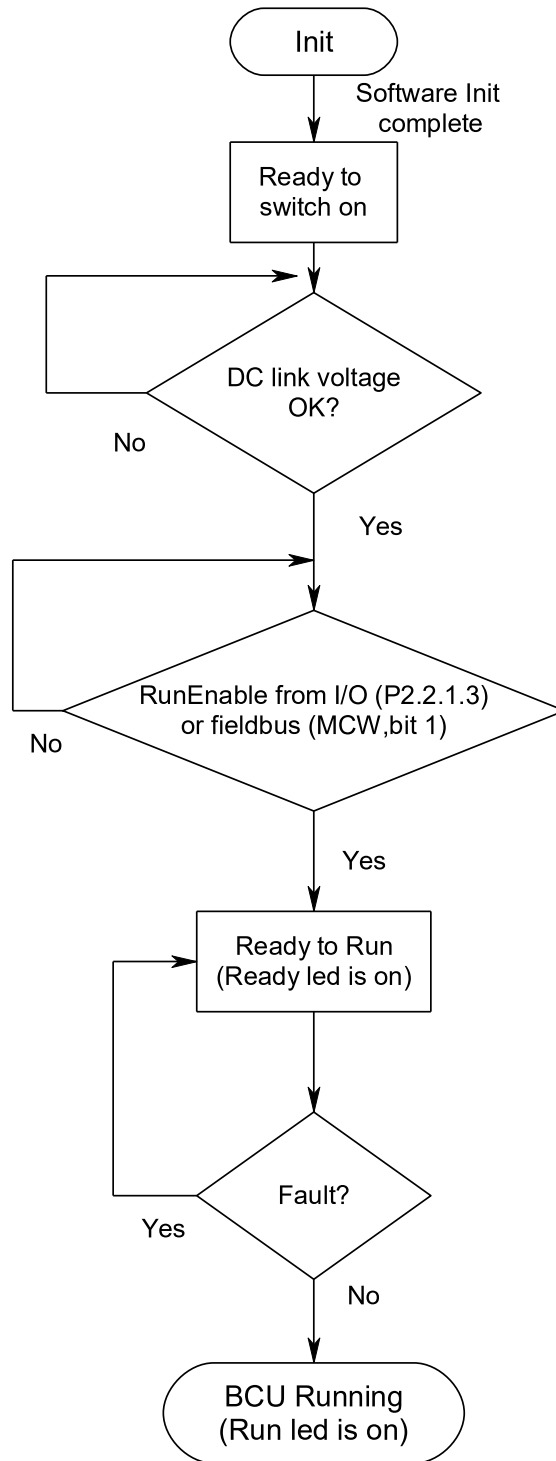

Figure 2. Start-up sequence

1.2 Quick start instructions

NOTE! Before taking any commissioning actions read carefully the safety instructions in Vacon NX User's Manual, chapter 1.

1. Check installations (see Figure 3, Table 2-1 and Table 2-2).
2. Check resistor(s) max. temperature durability.
3. Switch power on.
4. Set PT-100 parameters (P2.3.2.1, P2.3.2.2 and P2.5.2.1 – P2.5.2.3) or KLIXON input settings (P2.3.1.4).
5. Set brake chopper operation level to preferred value (P2.1.1).
6. In case of parallel BCU set Drooping (P2.2.1) = 5%.
7. Set Digital input parameters (P2.3.1.1 – P2.3.1.4) according to connections.
8. Test BCU. By making identification test P2.1.2 ID Run and then with normal operation.
9. If fault occurs see chapter 8.

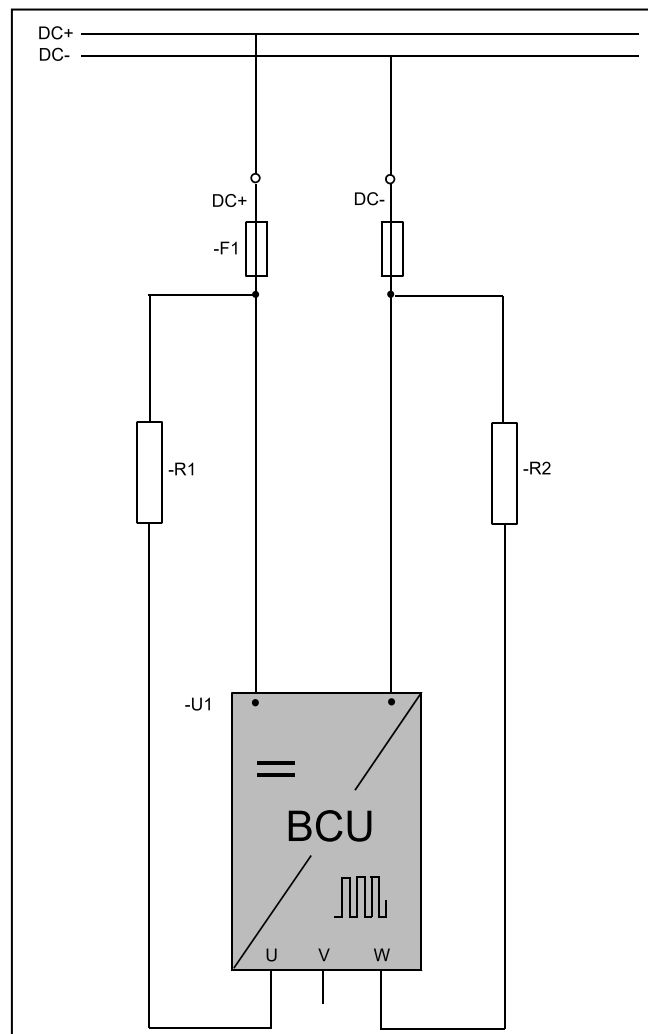

Figure 3. Resistor connections

2. CONTROL I/O



OPT-A1			
Terminal	Signal		Description
1	+10V _{ref}	Reference voltage	Maximum current 10 mA
2	AI1+	Analogue input 1, voltage or current	Default: 0– +10V (Ri = 200 kΩ) (-10V.....+10V Joy-stick control, selected with a jumper) 0– 20mA (Ri = 250 Ω)
3	AI1-	Analogue input common	Ground for reference and controls
4	AI2+	Analogue input 2	Same as AI1 but default is 0-20mA.
5	AI2-		
6	+24V	Control voltage output	Voltage for switches, etc. max 0.1 A
7	GND	I/O ground	Ground for reference and controls
8	DIN1	Digital input 1	Ri = min. 5kΩ 18...30V = "1"
9	DIN2	Digital input 2	
10	DIN3	Digital input 3 Fault Reset (Par. P2.2.1.1)	
11	CMA	Common for DIN 1—DIN 3	Connect to GND or +24V
12	+24V	Control voltage output	Voltage for switches (see #6)
13	GND	I/O ground	Ground for reference and controls
14	DIN4	Digital input 4	Ri = min. 5kΩ 18...30V = "1"
15	DIN5	Digital input 5	
16	DIN6	Digital input 6 Run enable (Par. P2.2.1.3)	
17	CMB	Common for DIN4—DIN6	Connect to GND or +24V
18	AO1+	Analogue output 1	Programmable Range 0—20 mA/R _L , max. 500Ω
19	AO1-		
20	DO1	Digital output READY (Par. P2.2.5)	Programmable Open collector, I _L ≤50mA, U _L ≤48 VDC
OPT-A2			
21	RO1		Relay output 1 Running
22	RO1		
23	RO1		
24	RO2		Relay output 2 Fault
25	RO2		
26	RO2		
			Switching capacity 24VDC/8A 250VAC/8A 125VDC/0.4A Min. switching load 5V/10mA
			Switching capacity 24VDC/8A 250VAC/8A 125VDC/0.4A Min. switching load 5V/10mA

Table 2- 1. Default I/O configuration.

OPT-B8			
Terminal	Signal		Technical information
1	R1 +	AnIN:X.1	PT100 Input, -30...200°C, one sensor. Accuracy ≤ 1°C. Sensor current 10 mA.
2	Rm1		
3	R1 -		
4	R2 +	AnIN:X.2	PT100 Input, -30...200°C, one sensor. Accuracy ≤ 1°C. Sensor current 10 mA.
5	Rm2		
6	R2 -		
7	R3 +	AnIN:X.3	PT100 Input, -30...200°C, one sensor. Accuracy ≤ 1°C. Sensor current 10 mA.
8	Rm3		
9	R3 -		
10	NC		Not connected

Table 2- 2. I/O terminals on OPT-B8

3. BRAKE CHOPPER APPLICATION – PARAMETER LISTS

On the next pages you will find the lists of parameters within the respective parameter groups.

Column explanations:

Code number	=	Location indication on the keypad; Shows the operator the present parameter
Parameter	=	Name of parameter
Default	=	Value preset by factory
Min	=	Minimum value of parameter
Max	=	Maximum value of parameter
Unit	=	Unit of parameter value; given if available
ID	=	ID number of the parameter (used with PC tools and fieldbus)
Note	=	Description of parameter

3.1 Monitoring values (Control keypad: menu M1)

The monitoring values are the actual values of parameters and signals as well as statuses and measurements. Monitoring values cannot be edited.

See Vacon NX User's Manual, Chapter 7 for more information.

3.1.1 Monitoring values 1

Code	Parameter	Unit	ID	Note
V1.1	Total Current	A	1104	Filtered braking current in Amperes.
V1.2	Power	kW	1106	Braking power in kW.
V1.3	DC-link Voltage	V	1108	DC intermediate voltage in Volts
V1.4	Current U	A	1149	Average current of U phase
V1.5	Current W	A	1151	Average current of W phase
V1.6	Unit Temperature	°C	1109	Unit temperature C-degrees.
V1.7	Analogue Input 1	%	13	
V1.8	Analogue Input 2	%	14	
V1.9	Analogue Input 3	%	27	
V1.10	Analogue Input 4	%	28	
V1.11	Analogue Output 1	%	1112	Analog Output 1 in%
V1.12	DIN1, DIN2, DIN3		15	Digital Inputs A1, A2 and A3 Status (sum)
V1.13	DIN4, DIN5, DIN6		16	Digital Inputs B4, B5 and B6 Status (sum)
V1.14	DO1, RO1, RO2		17	Digital Output and Relay 1&2 Status (sum)
V1.15	PT100(1) Temperature	°C	50	Temperature measured with PT100 sensor 1
V1.16	PT100(2) Temperature	°C	51	Temperature measured with PT100 sensor 2 (only when OPT-B8 is used)
V1.17	PT100(3) Temperature	°C	52	Temperature measured with PT100 sensor 3 (only when OPT-B8 is used)

Table 3-1. Monitoring values

3.1.2 Monitor 2

Code	Parameter	Unit	ID	Note
V1.18.1	Status Word		43	
V1.18.2	DC Voltage	Vdc	44	Unfiltered
V1.18.3	Current		1113	
V1.18.4	Phase U	%	39	
V1.18.5	Phase W	%	41	Average current of V phase

3.1.3 Fieldbus monitoring

Code	Parameter	Unit	ID	Note
V1.19.1	MainControlWord		1160	See the chapter 6
V1.19.2	MainStatusWord		1162	See the chapter 6
V1.19.3	Fault Word 1		1172	
V1.19.4	Fault Word 2		1173	
V1.19.5	Alarm Word		1174	
V1.19.6	Active Fault		37	Active fault code
V1.19.7	DIN Status Word 1		56	
V1.19.8	DIN Status Word 2		57	
V1.19.19	AuxControlWord 1		1161	

3.2 Description of monitoring values

3.2.1 Monitoring 1 values

V1.1 *Total Current* *A* *ID 1104*

Average sum current of all breaking phases.

V1.2 *Power* *kW* *ID 1106*

BCU breaking power in kW.

V1.3 *DC-Link Voltage* *V* *ID44*

Measured DC voltage.

V1.4 *Current U* *A* *ID119*

Average current of phase U

V1.5 *Current W* *A* *ID1151*

Average current of phase W

V1.6 *Unit Temperature* *°C* *ID 1109*

Heat sing temperature

V1.7 *Analogue Input 1* *%* *ID13*

V1.8 *Analogue Input 2* *%* *ID14*

V1.9 *Analogue input 3* *%* *ID 27*

V1.10 *Analogue input 4* *%* *ID 28*

Unfiltered analogue input level.

0 % = 0 mA / 0 V,

100 % = 20 mA / 10 V.

V1.11 *Analogue Out 1* *%* *ID 1112*

Analogue Output value 0 % = 0 mA / 0 V, 100 % = 20 mA / 10 V

V1.12 *DIN1, DIN2, DIN3* *ID 15*

V1.13 *DIN4, DIN5, DIN6* *ID 16*

	DIN1/DIN2/DIN3 status	DIN4/DIN5/DIN6 status
b0	DIN3	DIN6
b1	DIN2	DIN5
b2	DIN1	DIN4

V1.14 DO, R01, R02 ID 17

	D01/R01/R02 status
b0	R02
b1	R01
b2	D01

V1.15 PT100 Temp. 1 °C ID 50

V1.16 PT100 Temp. 2 °C ID 51

V1.17 PT100 Temp. 3 °C ID 52

The signal has 4 s filtering time.

3.2.2 Monitoring 2 Values

V1.18.1 Status Word (Application) ID 43

Application Status Word combines different drive statuses to one data word.

Application Status Word ID43		
	FALSE	TRUE
b0		
b1	Not in Ready state	Ready
b2	Not Running	Running
b3	No Fault	Fault
b4		
b5		
b6	Run Disabled	Run Enable
b7	No Warning	Warning
b8		
b9		
b10		BCU braking active
b11		
b12	No Run Request	Run Request
b13		
b14		
b15		

V1.18.2 DC Voltage V ID44

Measured DC voltage, unfiltered.

V1.18.3 Current ID1113

Unfiltered current. Scaled.

V1.18.4 Current U % ID39

Average current of V phase

V1.18.5 Current W % ID41

Average current of W phase

3.2.3 Fieldbus monitoring values

V1.19.1 Main Control Word ID 1160

Control word from fieldbus. Below table is for bypass operation for such fieldbus board that natively supports this or can be parameterized to bypass mode.

Main Control Word in ByPass mode		
	FALSE	TRUE
b0		
b1	Run is disabled, drive will not go to Run state.	Run is enabled
b2		
b3		
b4		
b5		
b6		
b7		> Fault Reset
b8		
b9		
b10	FB Control not active	FB Control active
b11	FB Watchdog pulse, Response fault when FB fault delay > 0.00 s (FB DIN1)	
b12	Fieldbus DIN2=OFF	Fieldbus DIN2=ON (Can be used to control R0)
b13	Fieldbus DIN3=OFF	Fieldbus DIN3=ON (Can be used to control R0)
b14	Fieldbus DIN4=OFF	Fieldbus DIN4=ON (Can be used to control R0)
b15		

V1.19.2 Main Status Word ID 1162

Status word to fieldbus. Below table is for bypass operation for such fieldbus board that natively supports this or can be parameterized to bypass mode.

Main Status Word in ByPass mode		
	FALSE	TRUE
b0	Not Ready	Ready
b1	Not ready to operate	Ready to operate
b2	Not Running	Running
b3	No Fault	Drive Faulted
b4	Coast stop not active	Coast stop active
b5		
b6		
b7	No Warning	Warning
b8		
b9	No Control from fieldbus	Control from fieldbus
b10		
b11		
b12		
b13		
b14		
b15	FB Watchdog pulse, MainControlWord B11 send back to PLC	

V1.19.3 *Fault Word 1* ID 1172

	FALSE	TRUE
b0		F1 Over current,
b1		F2 Over Voltage
b2		F9 Under Voltage
b3		
b4		F3 Earth Fault
b5		
b6		F14 Unit Over Temperature
b7		F56 PT-100, F29 Thermistor F60 Klixon
b8		
b9		
b10		Device Fault
b11		
b12		
b13		
b14		
b15		

V1.19.4 *Fault Word 2* ID 1173

	FALSE	TRUE
b0		
b1		
b2		
b3		Drive Hardware Fault
b4		Under temperature
b5		EEPROM or Checksum Fault
b6		F51 External fault
b7		
b8		Internal Communication Fault
b9		F31 IGBT, F41 IGBT
b10		
b11		F32 Cooling Fan Fault F62 Cooling Heat Exchange
b12		Application Fault
b13		Drive Internal Fault
b14		
b15		

V1.19.5 *Warning Word 1* ID 1174

	FALSE	TRUE
b0		
b1		W61 Thermistor, W56 PT-100
b2		
b3		
b4		
b5		
b6		
b7		
b8		Drive Over temperature Warning
b9		
b10		
b11		
b12		
b13		
b14		
b15		

V1.19.6 *Last Active Fault* ID37

Last active fault number.

V1.19.7 *DIN Status 1* ID 56

V1.19.8 *DIN Status 2* ID 57

	DIN StatusWord 1	DIN StatusWord 2
b0	DIN: A.1	DIN: C.5
b1	DIN: A.2	DIN: C.6
b2	DIN: A.3	DIN: D.1
b3	DIN: A.4	DIN: D.2
b4	DIN: A.5	DIN: D.3
b5	DIN: A.6	DIN: D.4
b6	DIN: B.1	DIN: D.5
b7	DIN: B.2	DIN: D.6
b8	DIN: B.3	DIN: E.1
b9	DIN: B.4	DIN: E.2
b10	DIN: B.5	DIN: E.3
b11	DIN: B.6	DIN: E.4
b12	DIN: C.1	DIN: E.5
b13	DIN: C.2	DIN: E.6
b14	DIN: C.3	
b15	DIN: C.4	

V1.19.9 AuxControlWord 1 ID 1161

Aux Control Word 1 ID1161		
	FALSE	TRUE
b0		
b1		
b2		
b3		
b4		
b5		
b6		
b7	No Action	Ext relay is forced open
b8		
b9		
b10		
b11		
b12		
b13		
b14		
b15		

4. PARAMETER LIST

In this document you will find the lists of parameters and monitoring values which are available in this application.

4.1 Basic parameters

Code	Parameter	Default	Min	Max	Unit	ID	Note
P2.1.1	Brake Chopper Level	648	Varies	Varies	V	1267	Brake chopper operation level in volts
P2.1.2	ID Run	0	0	1		631	Identification for brake resistor connection. If connection is changed after first power up remake identification.

Table 3-2. Basic parameters G2.1

4.2 Reference Handling

Code	Parameter	Default	Min	Max	Unit	ID	Note
P2.2.1	Drooping	0	0,00	100,00	%	620	Increase in braking current will increase the DC link voltage level for operation as a function of drooping.

Table 3-2. Basic parameters G2.1

4.3 Input signals

4.3.1 Digital inputs

Code	Parameter	Default	Min	Max	Unit	ID	Note
P2.3.1.1	Fault Reset	3	0	6		1208	Input Selection for Fault Resetting. 0 = Not used 1 = DIN1 2 = DIN2 3 = DIN3 4 = DIN4 5 = DIN5 6 = DIN6
P2.3.1.2	External Fault	0	0	6		1214	Digital input selection for external fault signal connection. As par. P2.3.1.1
P2.3.1.3	Run Enable	6	0	6		1212	Input selection for Run Enable Ctrl. 0 = Run Enabled internally As par. P2.3.1.1
P2.3.1.4	KLIXON	0	0	6		1209	Input Selection for KLIXON type Temperature Sensor. As par. P2.3.1.1
P2.3.1.5	Cooling Monitor	0	0	6		750	
P2.3.1.6	Run Request	0	0	6		1896	

Table 3-3. Digital input parameters

4.3.2 Analogue inputs

Code	Parameter	Default	Min	Max	Unit	ID	Note
P2.3.2.1	PT100 Analog Input selection	0	0	2		1221	Select the Analog input for connecting PT100 Sensor. 0=Not Used, 1=AI1, Slot A First input 2=AI2, Slot A Second input
P2.3.2.2	PT100 In Series	0	0	2		1222	Number of PT100 elements in series. 0=1*PT100, 1=2*PT100, 2=3*PT100.
P2.3.2.3	AI1 Signal Selection	A.1	0.1	E.10		377	
P2.3.2.3	AI2 Signal Selection	A.2	0.1	E.10		388	
P2.3.2.3	AI3 Signal Selection	0.1	0.1	E.10		141	
P2.3.2.3	AI4 Signal Selection	0.1	0.1	E.10		152	

Table 3-4. Analog input parameters G2.2.2

4.4 Output signals

4.4.1 Digital outputs

Code	Parameter	Default	Min	Max	Unit	ID	Note
P2.4.1.1	D01 Ctrl	1	0	14		1216	Signal Selection for D01
P2.4.1.2	D02 Ctrl	2	0	14		1217	Signal selection for D02 (R01)
P2.4.1.3	D03 Ctrl	3	0	14		1218	Signal selection for D03 (R02)
P2.4.1.4	D04 Ctrl	0	0	14		1385	Signal Selection for D04
P2.4.1.5	D05 Ctrl	0	0	14		1386	Signal selection for D05
P2.4.1.6	D06 Ctrl	0	0	14		1390	Signal selection for D06
P2.4.1.7	D07 Ctrl	0	0	14		1391	Signal Selection for D07
P2.4.1.8	D08 Ctrl	0	0	14		1395	Signal selection for D08
P2.4.1.9	D09 Ctrl	0	0	14		1396	Signal selection for D09
P2.4.1.10	D010 Ctrl	0	0	14		1423	Signal Selection for D010
P2.4.1.11	D011 Ctrl	0	0	14		1427	Signal selection for D011
P2.4.1.12	D012 Ctrl	0	0	14		1428	Signal selection for D012
P2.4.1.13	D013 Ctrl	0	0	14		1429	Signal selection for D013

Table 3-5. Digital output parameters

4.4.2 Analogue output 1

Code	Parameter	Default	Min	Max	Unit	ID	Note
P2.4.2.1	A01 Signal ID	0	0	2000		1233	Set the ID no. of a signal to be connected to A01
P2.4.2.2	A01 Offset	0	0	1		1234	Minimum voltage or current at A01. 0= 0V/0mA, 1= 4mA
P2.4.2.3	A01 Filter	10	0,02	10,00	s	1235	Filter time for the signal selected for A01 in Seconds.
P2.4.2.4	A01 Max. Value	1500	-30000	30000		1236	Maximum value of a signal selected for A01. This will correspond to +10V/20mA.
P2.4.2.5	A01 Min. Value	0	-30000	30000		1237	Minimum value of a signal connected to A01. This will correspond to 0V/0mA or 2V/4mA depending on the type of A01.

Table 3-6. Analogue output parameters

4.4.3 Output Options

Code	Parameter	Default	Min	Max	Unit	ID	Note
P2.4.3.1	Fan Off Delay	0	0	32000	S	1320	Fan control, started when actual breaking is made. Off after delay.

Table 3-2. Output Options G2.4

4.5 Protections

4.5.1 General

Code	Parameter	Default	Min	Max	Unit	ID	Note
P2.5.1.1	Thermistor	1	0	2		1351	Response to thermistor overtemperature. 0=No Action, 1=Warning, 2=Fault
P2.5.1.2	External Fault	2	0	2		701	Response to External fault. 0=No action, 1=Warning, 2=Fault

Table 3-9. Protections

4.5.2 PT-100

Code	Parameter	Default	Min	Max	Unit	ID	Note
P2.5.2.1	PT100 Numbers	0	0	3		739	Number of PT100 inputs in use at OPT-B8 option board. Visible only when the option board has been installed
P2.5.2.2	PT100 Alarm Lim	110	-30	200	°C	1347	Select the temperature for PT100 sensor above which PT100 alarm is generated in the drive.
P2.5.2.3	PT100 Fault Lim	120	-30	300	°C	1348	Select the temperature for PT100 sensor above which PT100 fault is generated in the drive

Table 3-9. Protections

4.5.3 Fieldbus

Code	Parameter	Default	Min	Max	Unit	ID	Note
P2.5.3.1	FB WatchdogDelay	1.1	0	5.00	s	1354	Fieldbus watchdog delay. If set to 0 watchdog function is disabled.
P2.5.3.2	FBComm.FaultResp	2	0	2		733	0 = No Action 1 = Warning 2 = Fault

Table 3-9. Protections G2.6

4.5.4 Cooling Monitoring

Code	Parameter	Default	Min	Max	Unit	ID	Note
P2.5.4.1	Cooling Fault Delay	5,00	0,00	10,00	s	751	
P2.5.4.2	Cooling Fault Response	0	0	3		762	0= No Action, Warning 1= Warning, Warning 2= Warning, Fault 3= No Action, Fault

Table 3-9. Protections G2.5.4

4.5.5 Fault Simulation

Code	Parameter	Default	Min	Max	Unit	ID	Note
P2.6	Fault Simulation	0	0	65535		1569	

Table 3-9. Protections G2.6

4.6 Fieldbus parameters

Code	Parameter	Default	Min	Max	Unit	ID	Note
P2.6.1	Fieldbus data out 1 selection	1104	0	65535		1490	Choose monitoring data with parameter ID
P2.6.2	Fieldbus data out 2 selection	1106	0	65535		1491	Choose monitoring data with parameter ID
P2.6.3	Fieldbus data out 3 selection	37	0	65535		1492	Choose monitoring data with parameter ID
P2.6.4	Fieldbus data out 4 selection	0	0	65535		1493	Choose monitoring data with parameter ID
P2.6.5	Fieldbus data out 5 selection	0	0	65535		1494	Choose monitoring data with parameter ID
P2.6.6	Fieldbus data out 6 selection	0	0	65535		1495	Choose monitoring data with parameter ID
P2.6.7	Fieldbus data out 7 selection	0	0	65535		1496	Choose monitoring data with parameter ID
P2.6.8	Fieldbus data out 8 selection	0	0	65535		1497	Choose monitoring data with parameter ID
P2.6.9	Fieldbus data in 1 selection	0	0	10000		876	Choose controlled data with parameter ID
P2.6.10	Fieldbus data in 2 selection	0	0	10000		877	Choose controlled data with parameter ID
P2.6.11	Fieldbus data in 3 selection	0	0	10000		878	Choose controlled data with parameter ID
P2.6.12	Fieldbus data in 4 selection	0	0	10000		879	Choose controlled data with parameter ID
P2.6.13	Fieldbus data in 5 selection	0	0	10000		880	Choose controlled data with parameter ID
P2.6.14	Fieldbus data in 6 selection	0	0	10000		881	Choose controlled data with parameter ID
P2.6.15	Fieldbus data in 7 selection	0	0	10000		882	Choose controlled data with parameter ID
P2.6.16	Fieldbus data in 8 selection	0	0	10000		883	Choose controlled data with parameter ID

Table 3-8. Fieldbus parameters G2.6

4.7 ID Control Functions

4.7.1 DIN ID Control

Code	Parameter	Min	Max	Unit	Default	Cust	ID	Note
P2.7.1.1	ID Control DIN	0.1	E.10		0.1		1570	Slot . Board input No. If 0.1 ID61 can be controlled from FB
P2.7.1.2	Controlled ID	0	10000	ID	0		1571	Select ID that is controlled by digital input
P2.7.1.3	False value	-32000	32000		0		1572	Value when DI is low
P2.7.1.4	True value	-32000	32000		0		1573	Value when DI is high

Table 4-1. DIN ID Control parameters, G2.2.8

4.7.2 DIN ID Control

Code	Parameter	Min	Max	Unit	Default	Cust	ID	Note
P2.7.2.1	ID Control DIN	0.1	E.10		0.1		1590	Slot . Board input No. If 0.1 ID61 can be controlled from FB
P2.7.2.2	Controlled ID	0	10000	ID	0		1575	Select ID that is controlled by digital input
P2.7.2.3	False value	-32000	32000		0		1592	Value when DI is low
P2.7.2.4	True value	-32000	32000		0		1593	Value when DI is high

Table 4-2. DIN ID Control parameters, G2.2.8

4.8 Keypad control (Control keypad: Menu M3)

Code	Parameter	Default	Min	Max	Unit	ID	Description
P3.1	Control place	0	0	1		125	0=I/O terminal (default) 1=Fieldbus

Table 3-10. Keypad control parameters M3

4.9 System menu (Control keypad: Menu M6)

For parameters and functions related to the general use of the frequency converter, such as application and language selection, customised parameter sets or information about the hardware and software, see Chapter 7.3.6 in the Vacon NX User's Manual.

4.10 Expander boards (Control keypad: Menu M7)

The **M7** menu shows the expander and option boards attached to the control board and board-related information. For more information, see Chapter 7.3.7 in the Vacon NX User's Manual.

5. DESCRIPTION OF PARAMETERS

5.1 Basic parameters

2.1.1 Brake Chopper Level (ID1267)

Brake chopper operation level in volts. This is the DC link voltage level when the BCU starts to discharge the capacitors through the brake resistor.

Below table is only guide line what common DC voltages are with and without AFE.

Line voltage	AC -> DC	DC voltage	AFE Voltage boost (Default)	DC voltage
400 Vac	1,35	540 Vdc	110 %	594 Vdc
500 Vac		675 Vdc		743 Vdc
690 Vac		932 Vdc		1025 Vdc

2.1.2 ID Run (ID631)

This parameter is used for manual identification for brake resistor connection. Brake chopper unit makes automatic identification during first power up. However, if resistor connection are changed after first power-up ID Run can be executed manually again with this parameter by setting the value "1=ID Run".

1 = No action

2 = ID Run

Drive identifies configuration of brake resistors.

5.2 Reference Handling

2.2.1 *Drooping* (ID1501)

Increase in braking current will increase the DC link voltage level for operation as a function of drooping. This parameter is applicable only when there is more than one BCU connected in parallel.

5.3 Input signals

5.3.1 Digital Inputs

2.3.1.1 *Fault Reset (ID1208)*

Input selection for Fault Resetting. The transition from Off to On will reset the fault if the cause of the fault has been removed.

- 0 = Not used
- 1 = DIN1
- 2 = DIN2
- 3 = DIN3
- 4 = DIN4
- 5 = DIN5
- 6 = DIN6

2.3.1.2 *External fault (ID1214)*

This parameter defines if the BCU monitors status of the External fault input. With External fault it is possible to trig a fault 51. Response to the fault can be defined with the parameter [P2.5.1.2](#)

See parameter [P2.3.1.1](#) for the list of values.

2.3.1.3 *Run Enable (ID1212)*

This parameter is used for choosing the input for external Run Enable signal. If the option "0 = Not used" have been selected the Run Enable signal is always on.

See parameter [P2.3.1.1](#) for the list of values.

2.3.1.4 *KLIXON Input (ID1209)*

This parameter is used for choosing the input for KLIXON type temperature sensor. The function of this input is Normally Closed so the fault "60 = KLIXON" is generated when the input goes low.

See parameter [P2.3.1.1](#) for the list of values.

2.3.1.5 *Cooling Monitoring ID750*

When using a liquid-cooled drive, connect this input to the Cooling OK signal from Vacon flow control application or any input that shows state of used cooling unit. See details of operation from G2.5.4 cooling parameters group.

2.3.1.6 *Run Request ID1896*

Start command, normal used Run Enable removes drive ready state, use this input if Ready signal is monitored for e.g. start command purposes.

5.3.2 Analogue Inputs

2.3.2.1 PT100 Analog Input selection (ID1221)

Selects the analogue input to be used for temperature measurement using PT100 sensor.

In BCU application you can use either Analogue input or OPT-B8 option board for PT100 connection. Both ways can not be used at the same time. If Analogue input has been used for PT100 measurement the Analogue Output 1 is forced to 10mA level and it is used as a power supply for PT100 sensor. Connection has been illustrated in Figure 4.

0 = Not used

1 = AI1, Fixed to Slot A First Input

2 = AI2, Fixed to Slot A Second Input

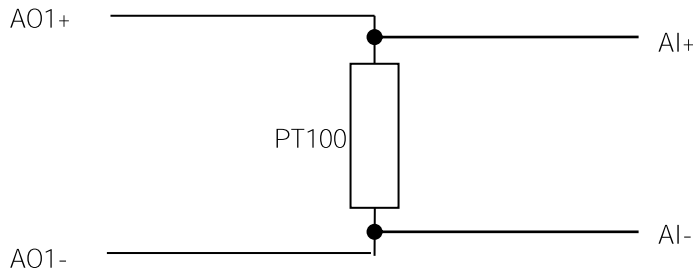

Figure 4. PT100 connection.

2.3.2.2 PT100 In Series (ID1222)

Selects the number of PT100 elements connected in series.

0 = 1 * PT100

1 = 2 * PT100

2 = 3 * PT100

5.3.3 Analogue Inputs 1-4

2.3.2.3 AI1 signal selection ID377 "AI1 Signal Sel"

2.3.2.4 AI2 signal selection ID388 "AI2 Signal Sel"

2.3.2.5 AI3 signal selection ID141 "AI3 Signal Sel"

2.3.2.6 AI4 signal selection ID152 "AI4 Signal Sel"

Select analogue input for monitoring purposes. These selections do not affect PT100 input function when analogue input is used.

5.4 Output signals

5.4.1 Digital output signals

2.4.1.1 DO1 (ID1216)

Select the signal for controlling the DO1.

- 0 = Not used
- 1 = Ready
Drive in Ready state
- 2 = Running
Drive ready for breaking operation.
- 3 = Fault
Drive in Fault state
- 4 = No Fault
No fault in drive, inverted fault.
- 5 = Warning
Warning active.
- 6 = Braking active (BCU is braking)
Drive is feeding power to resistors.
- 7 = Fan Control
Fan control signal from drive Running status. Set off delay with P2.4.3.1 Fan Off Delay.
- 8 = Resistor Cooling
Fan control signal from Breaking status. Fan is started when power is fed to the resistors. Set off delay with
- 9 = External Relay Control

External Relay ON/OFF control

Example: OPTA2 board R01 :

Relay function ON: Terminals 22-23 are connected (Relay is energized).

Relay function OFF: Terminals 22-23 are open (Relay not energized).

Relay Open Command
Relay function OFF

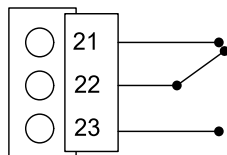

Relay Close Command
Relay function ON

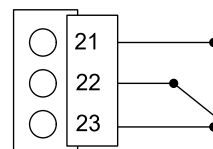

10 = External Relay Control, Inverted

Example: OPTA2 board R01 :

Relay function ON: Terminals 22-23 are open. (Relay not energized)

Relay function OFF: Terminals 22-23 are connected. (Relay is energized).

Relay Open Command
Relay function OFF

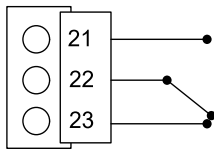

Relay Close Command
Relay function ON

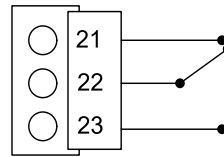

11 = Fieldbus digital input data 2
12 = Fieldbus digital input data 3
13 = Fieldbus digital input data 4

The data from the Fieldbus main control word can be led to the drive's digital outputs. See used fieldbus board manual for location of these bits. Note that FB Dig Input 1 is already used for fieldbus watch dog

14 = Charge switch ready

2.4.1.2 DO2 (ID1217)

Select the signal for controlling the relay output 1 (R01) of relay option board.

See parameter [P2.4.1.1](#) for the list of values.

2.4.1.3 DO3 (ID1218)

Select the signal for controlling the relay output 2 (R02) of relay option board.

See parameter [P2.4.1.1](#) for the list of values.

2.4.1.4- 2.4.1.13 DO4 – DO13 (ID1385 – ID1429)

These parameters are only visible when there are additional option boards with digital outputs installed in the BCU. If for example the option board OPT-B5 has been installed the parameters for outputs DO4-DO6 become visible.

See parameter [P2.4.1.1](#) for the list of values.

5.4.2 Analogue output 1

2.4.2.1 Analogue Output 1 signal ID (ID1233)

Set the ID no. of a signal to be connected to AO1. To connect e.g. DC-link voltage to Analogue output 1, enter 1108 as parameter value.

NOTE! If Analogue input has been chosen to be used for PT100 measurement (P2.3.2.1 > 0) the Analogue Output 1 is forced to 10mA level.

2.4.2.2 Analogue Output 1 Offset (ID1234)

Minimum voltage or current at AO1.

0 = 0V/0mA,

1 = 4mA

2.4.2.3 Analogue Output Filter time (ID1235)

Defines filtering time of the analogue output signal.

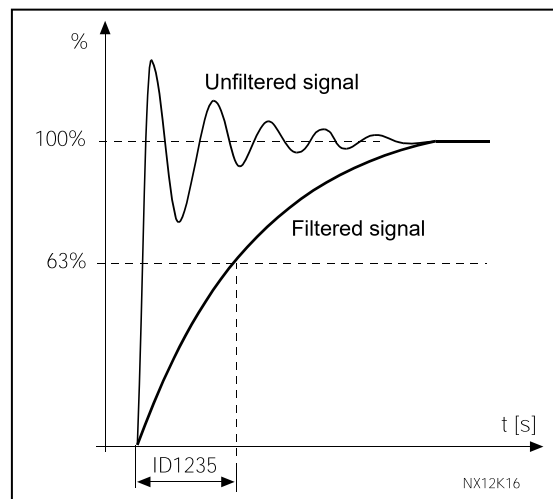

Figure 5. Analogue output filtering

2.4.2.4 Analogue Output Maximum value (ID1236)

Maximum value of a signal selected for AO1. This will correspond to +10V/20mA.

2.4.2.5 Analogue Output Minimum value (ID1237)

Minimum value of a signal selected for AO1. This will correspond to 0V/0mA or 2V/4mA depending on the type of AO1.

5.4.3 Output options

P2.4.3.1 Fan Off Delay ID1320

Fan off delay control for digital output functions 7 and 8.

5.5 Protections

5.5.1 General

2.5.1.1 *Response to thermistor fault (ID1351)*

- 0 = No response
- 1 = Warning
- 2 = Fault

2.5.1.2 *Response to External fault (ID1351)*

- 0 = No response
- 1 = Warning
- 2 = Fault

This parameter defines a response to an external fault. If the BCU monitors state of the external fault input (value of P2.3.1.2 > 0) and a fault occurs the drive can be set to respond to the fault.

5.5.2 PT-100

2.5.2.1 *Number of PT100 inputs in use*

If you have a PT100 input board (OPTB8) installed in your BCU you can choose here the number of PT100 inputs in use. See also the Vacon I/O boards manual.

Note: If the selected value is greater than the actual number of used PT100 inputs, the display will read 200°C. If the input is short-circuited the displayed value is -30°C.

This parameter is visible only when there is OPTB8 option board installed in the BCU.

2.5.2.2 *PT100 Alarm limit (ID1347)*

Set here the limit at which the PT100 alarm will be activated.

2.5.2.3 *PT100 Fault limit (ID1348)*

Set here the limit at which the PT100 fault will be activated.

Setting the parameter to 0 will deactivate the protection.

5.5.3 Fieldbus

2.5.3.1 *Fieldbus communication fault response (ID733)*

- 0 = No Action
No action in case on Fieldbus communication fault. Note: Some Fieldbus board may stop the drive even if no response is selected.
- 1 = Warning
- 2 = Fault

2.5.3.2 *Fieldbus watchdog delay (ID1354)*

Delay time to indicate a loss of data on a fieldbus from an overriding system. The overriding system sends a watchdog signal (square wave of 1 second time period) at Main control word. Bit11. If the drive does not receive this signal for a time higher than the time defined by this parameter, the drive trips on fault F53 Fieldbus communication. The fault occurs only if the drive is controlled from fieldbus.

The same watchdog signal is sent back to the overriding system at Main status word. Bit15.

Setting this parameter to zero will disable this watchdog monitoring function. In addition to this, the fieldbus option card monitors communication with the fieldbus master and is always active. In case of loss of communication with the master, the drive trips on F53 Fieldbus communication fault.

5.5.4 *Cooling Monitoring*

Protection for liquid cooled units. An external sensor is connected to the drive (DI: Cooling Monitor) to indicate if cooling liquid is circulating.

P2.12.9.1 *Cooling fault delay ID751 "Cooling F Delay"*

This parameter defines the delay after which the drive goes to fault state when 'Cooling OK' signal is missing.

P2.12.9.2 *Cooling fault response ID762 "CoolingFaultREsp"*

In some cases it is more important to allow the drive to run even if the cooling liquid is not circulating. Then it is possible to select warning as the response. The drive will then continue running until its internal protection will stop it. If cooling signal loss happens on stop state indication is not stored to fault history if previous fault is already Cooling Fault. In Run State indication is always stored to fault history

0 = Stop State: No Action, Run State: Warning

1 = Stop State: Warning, Run State: Warning

2 = Stop State: Warning, Run State: Fault

3 = Stop State: No Action, Run State: Fault

5.5.5 *Fault Simulation*

2.6.8 *Fault Simulation (ID1569)*

With this parameter it's possible to simulate different faults without actually causing e.g. over current fault situation.

B00 = +1 = Simulates over current fault (F1)

B01 = +2 = Simulates over voltage fault (F2)

B02 = +4 = Simulates under voltage fault (F9)

B03 = +8 = Simulates output phase supervision fault (F11)

B04 = +16 = Simulates earth fault (F3)

B05 = +32 = Simulates system fault (F8)

B06 = +64 = Reserved

B07 = +128 = Simulates over temperature warning (W14)

B08 = +256 = Simulates over temperature fault (F14)

5.6 Fieldbus parameters

2.6.1 –

2.6.8 *Fieldbus data out 1-8 selection (ID1490-ID1497)*

Using these parameters, you can monitor any monitoring or parameter value from the fieldbus. Enter the ID number of the item you wish to monitor for the value of these parameters.

2.6.9 –

2.6.16 *Fieldbus data in 1-8 selection (ID876-ID883)*

Using these parameters, you can control any parameter value from the fieldbus. Enter the ID number of the item you wish to control for the value of these parameters.

5.7 ID Control Functions

5.7.1 DIN ID Control

This function is used to control any parameter between two different values with a digital input. Different values are given for DI 'low' and DI 'high'.

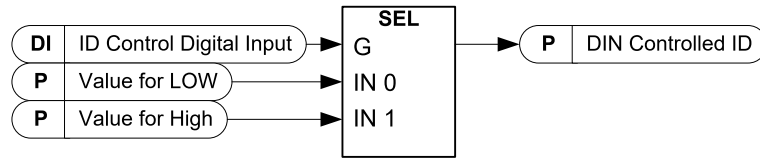

P2. 7.1.1 *ID Control Digital Input ID1570* **"ID Control DIN"**

P2. 7.2.1 *ID Control Digital Input ID1590* **"ID Control DIN"**

Select digital input to be used for controlling the parameter selected by ID1571.

P2. 7.1.2 *DIN Controlled ID ID1571* **"Controlled ID"**

P2. 7.2.2 *DIN Controlled ID ID1575* **"Controlled ID"**

Select parameter ID controlled by ID1570.

P2. 7.1.3 *Value for Low digital input (FALSE) ID1572* **"FALSE Value"**

P2. 7.2.3 *Value for Low digital input (FALSE) ID1592* **"FALSE Value"**

Set here the controlled parameter value when the digital input (ID1570) is LOW for the parameter selected by ID1571. The function does not recognize decimals. Give, therefore, e.g. 10.00 Hz as '1000'.

P2. 7.1.4 *Value for High digital input (TRUE) ID1573* **"TRUE Value"**

P2. 7.2.4 *Value for High digital input (TRUE) ID1593* **"TRUE Value"**

Set here the controlled parameter value when the digital input (ID1570) is HIGH for the parameter selected by ID1571. The function does not recognize decimals. Give, therefore, e.g. 10.00 Hz as '1000'.

5.8 Keypad control

3.1 *Control place (ID125)*

The active control place can be changed with this parameter.

0 = I/O terminal (default)

1 = Fieldbus

6. FIELDBUS PROFILE FOR VACON BRAKE CHOPPER UNIT

Following document describes fieldbus profile for Brake Chopper Unit application.

If Profibus, Modbus or CANopen is used then **Operate Mode = Bypass** is to be used to be able to read or write the following info.

6.1 Signals from Overriding System to Vacon regenerative Drive.

Fieldbus Data Name	Signal Name	Min	Max	FB Scale	Scaling Description
Control Word	Main Control Word				See bitwise description below
Reference Value					Reserved for future use.
Process Data IN1					Reserved for future use.
Process Data IN2					Reserved for future use.
Process Data IN3					Reserved for future use.
Process Data IN4					Reserved for future use.
Process Data IN5					Reserved for future use.
Process Data IN6					Reserved for future use.
Process Data IN7					Reserved for future use.
Process Data IN8					Reserved for future use.

Table 6-1. Signals from overriding system

6.2 Signals from Vacon Drive to Overriding system

Fieldbus Data Name	Signal Name	FB Scale	Scaling Description
Main Status Word	Main Status Word		See bitwise description below
Actual Value	DC Voltage	1=1V	DC Voltage in Volts
ProcessDataOut1	Total current	10=1A	Total Current
ProcessDataOut2	Power	10=1%	Power
ProcessDataOut3	Active fault		Active Fault
ProcessDataOut4			Reserved for future use.
ProcessDataOut5			Reserved for future use.
ProcessDataOut6			Reserved for future use.
ProcessDataOut7			Reserved for future use.
ProcessDataOut8			Reserved for future use.

Table 6-2. Signals to overriding system

6.3 Main Control Word

Main Control Word in ByPass mode		
	FALSE	TRUE
b0		
b1	Run is disabled, drive will not go to Run state.	Run is enabled
b2		
b3		
b4		
b5		
b6		
b7		> Fault Reset
b8		
b9		
b10	FB Control not active	FB Control active
b11	FB Watchdog pulse, Response fault when FB fault delay > 0.00 s (FB DIN1)	
b12	Fieldbus DIN2=OFF	Fieldbus DIN2=ON (Can be used to control RO)
b13	Fieldbus DIN3=OFF	Fieldbus DIN3=ON (Can be used to control RO)
b14	Fieldbus DIN4=OFF	Fieldbus DIN4=ON (Can be used to control RO)
b15		

Table 6-3. Main Control Word

6.4 Main Status Word

Main Status Word in ByPass mode		
	FALSE	TRUE
b0	Not Ready	Ready
b1	Not ready to operate	Ready to operate
b2	Not Running	Running
b3	No Fault	Drive Faulted
b4	Coast stop not active	Coast stop active
b5		
b6		
b7	No Warning	Warning
b8		
b9	No Control from fieldbus	Control from fieldbus
b10		
b11		
b12		
b13		
b14		
b15	FB WatchDog pulse, MainControlWord B11 send back to PLC	

Table 6-4. Main Status Word

7. PROBLEM SOLVING

While proper information is needed from the problem, it's also recommended to try with latest application- and system software versions available. Software is continuously developed and default settings are improved.

Type	Signal Name	Actual	Unit
Value	Status Word	5190	
Value	DC Voltage	691	V
Value	Current U	2,1	A
Value	Current W	2	A
Value	Total Current	4,2	A
Value	Power	2,8	kW
Value	Phase U	-0,7	%
Value	Phase W	-0,4	%

Figure 1. The recommended signals for NCDrive

Use the fastest communication speed (Baudrate: 57 600) and a 50 ms update interval for signals for the RS232 communication.

For the CAN communication, use a 1 Mbit communication speed and 7 ms (or less) update interval for signals.

When you contact the support, send the *.trn, *.par and Service info (*.txt) files with a description of the situation. If the situation is caused by a fault, take also the Datalogger data from the drive.

Note that Datalogger settings can be changed to catch correct situation and it's also to possible make manual force trig for Datalogger.

Before storing the parameter file, upload the parameters from the drive and save when NCDrive is in the ON-LINE state. If it is possible, do this while the problem is active.

It's also helpful to have single line diagram from the system where problem is faced.

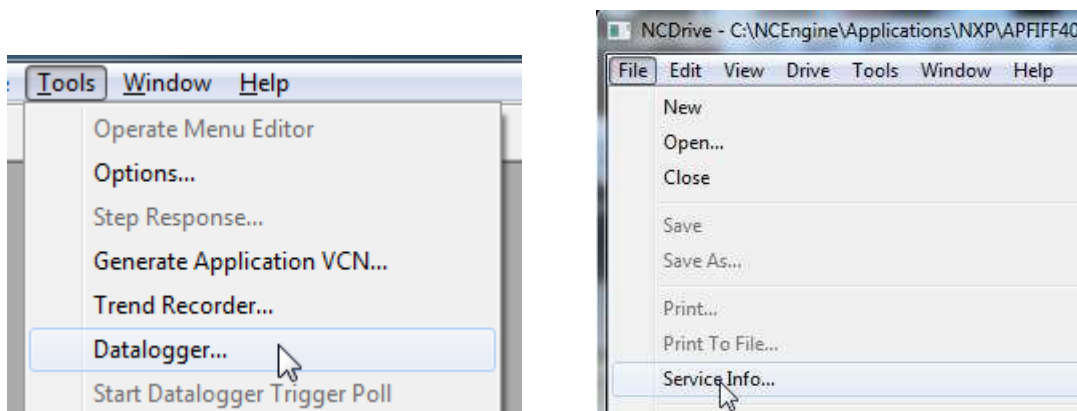

Figure 1. Datalogger window opening and Service Info upload.

8. FAULT CODES

The fault codes, their causes and correcting actions are presented in the table below. The shadowed faults are A faults only. The items written in white on black background present faults for which you can program different responses in the application. See parameter group Protections.

Note: When contacting distributor or factory because of a fault condition, always write down all texts and codes on the keypad display.

Fault code	Fault	Possible cause	Correcting measures
1	Overcurrent	BCU has detected too high current ($>4 \cdot I_H$) in the resistor cables:	- Check cables. - Check resistors
2	Overvoltage	The DC-link voltage has exceeded the limit: 911V for 500V BCU 1200V for 690V BCU	
7	Saturation trip	Various causes: - defective component - brake resistor short-circuit or overload	- Cannot be reset from the keypad. - Switch off power. - DO NOT RE-CONNECT POWER! - Contact your local distributor.
8	System fault	- component failure - faulty operation Note exceptional fault data record Subcode in T.14 : S1 = Reserved S2 = Reserved S3 = Reserved S4 = Reserved S5 = Reserved S6 = Reserved S7 = Charging switch S8 = No power to driver card S9 = Power unit communication (TX) S10 = Power unit communication (Trip) S11 = Power unit comm. (Measurement)	Reset the fault and restart. Should the fault re-occur, contact your local distributor.
9	Undervoltage	DC-link voltage is under the BCU fault voltage limit: 333VDC for 500V BCU 460VDC for 690V BCU - most probable cause: too low supply voltage in the system - BCU internal fault	- In case of temporary supply voltage break, reset the fault and restart the frequency converter. - Check the supply voltage. - If it is adequate, an internal failure has occurred. - Contact your local distributor. Please visit: http://www.vacon.com/wwcontacts.html
13	BCU under-temperature	Heatsink temperature is under -10°C	
14	BCU over-temperature	Heatsink temperature is over 90°C Overtemperature warning is issued when the heatsink temperature exceeds 85°C .	- Check the correct amount and flow of cooling air. - Check the heatsink for dust. - Check the ambient temperature.

18	Unbalance (Warning only)	Unbalance between power modules in paralleled units. Subcode in T.14 : S1 = Current unbalance S2 = DC-Voltage unbalance	Should the fault re-occur, contact your local distributor.
31	IGBT temperature (hardware)	IGBT Inverter Bridge overtemperature protection has detected too high short term overload current	
35	Application	Problem in application software	Contact your distributor. If you are application programmer check the application program.
37	Device changed (same type)	Option board or power unit changed. New device of same type and rating.	Reset. Device is ready for use. Old parameter settings will be used.
38	Device added (same type)	Option board added.	Reset. Device is ready for use. Old board settings will be used.
39	Device removed	Option board removed.	Reset. Device no longer available.
40	Device unknown	Unknown option board or drive. Subcode in T.14 : S1 = Unknown device S2 = Power1 not same type as Power2	Contact the distributor near to you.
41	IGBT temperature	IGBT Inverter Bridge overtemperature protection has detected too high a short term overload current	
42	Brake resistor	S1: Not available in BCU (High temp) S2: Brake resistor resistance is too high S3: Brake resistor resistance is too low S4: No brake resistor detected S5: Not available in BCU (High temp)	Check connection of brake resistor Change resistor to correct resistance
44	Device changed (different type)	Option board or power unit changed. New device of different type or different rating than the previous one.	Reset Set the option board parameters again if option board changed. Set converter parameters again if power unit changed.
45	Device added (different type)	Option board of different type added.	Reset Set the option board parameters again.
51	External fault	Digital input fault.	- Remove fault situation from external device.
54	Slot fault	Defective option board or slot	Check board and slot. Contact the nearest Vacon distributor.
56	PT100 fault	Temperature limit values set for the PT100 have been exceeded.	
60	KLIXON	Status of KLIXON input is LOW.	
61	Thermistor fault	The thermistor input of option board has detected too high resistor temperature	Check resistors. Check thermistor connection (If thermistor input of the option board is not in use it has to be short circuited)

Table 8-1. Fault codes

VAGON[®]

www.danfoss.com

Vacon Ltd
Member of the Danfoss Group

Runsorintie 7
65380 Vaasa
Finland

Document ID:



Rev. A